

SAT 120 S / LS

SLIDING SYSTEM

SAT 120 S / LS

SLIDING SYSTEM



ACCURACY



HARMONY



BALANCE

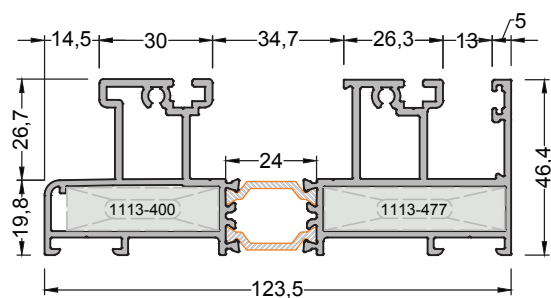

320-1202 (2,875 kg/mt)
SAT120 F07 FRAME PROFILE

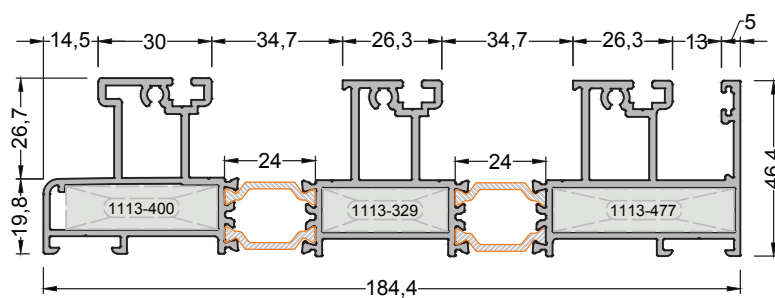

320-1302 (4,229 kg/mt)
SAT120 F05 FRAME PROFILE

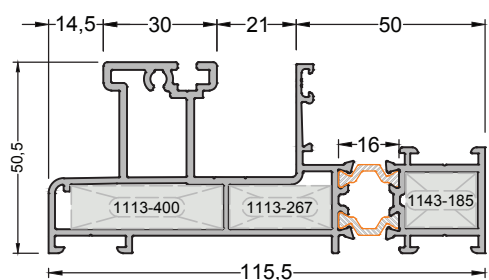

320-1102 (2,542 kg/mt)
SAT120 F10 FRAME PROFILE

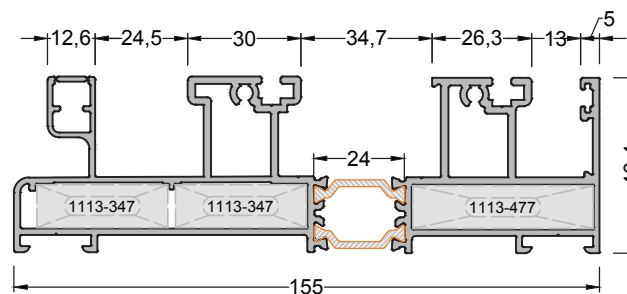

320-1203 (3,351 kg/mt)
SAT120 F11 FRAME PROFILE

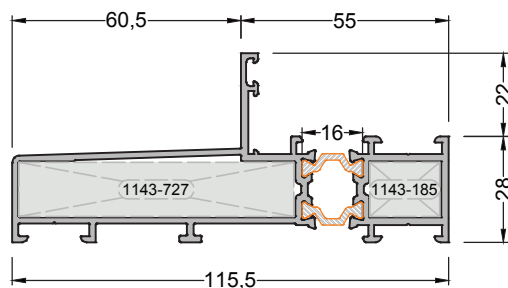

320-1404 (1,926 kg/mt)
SAT120F09 FRAME PROFILE

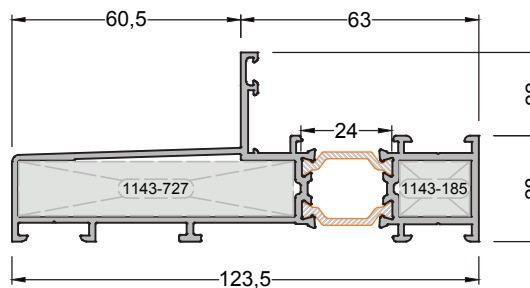

320-1403 (1,969 kg/mt)
SAT120F08 FRAME PROFILE

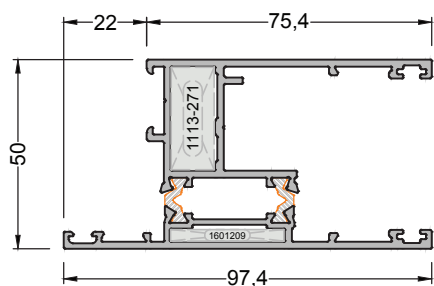

320-2101 (1,900 kg/mt)
SAT120V01 VENT PROFILE

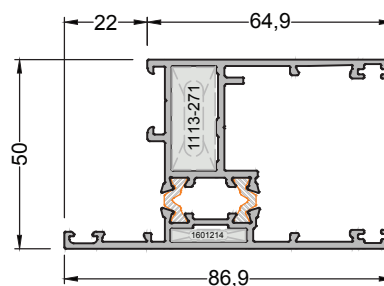

320-2102 (1,689 kg/mt)
SAT120V02 VENT PROFILE

SAT 120 S / LS

SLIDING SYSTEM

ACCURACY

HARMONY

BALANCE

WAT55M01 BELONGS TO WAT55 SERIES
ALL MEDIUM RECORDS CAN BE APPLIED

WAT55M01 BELONGS TO WAT55 SERIES
ALL MEDIUM RECORDS CAN BE APPLIED

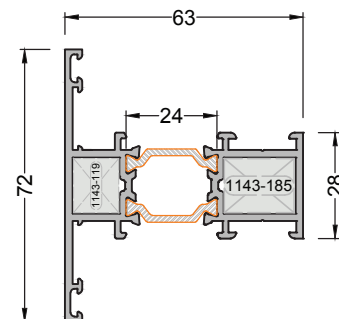
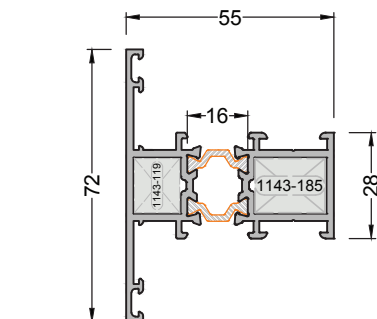
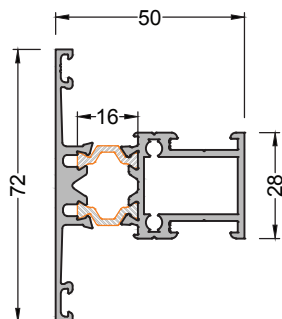

320-3101 (1,347 kg/mt)
SAT120M01 MULLION PROFILE

255-2101 (1,505 kg/mt)
WAT55M01 MULLION PROFILE

263-2101 (1,546 kg/mt)
WAT63M01 MULLION PROFILE

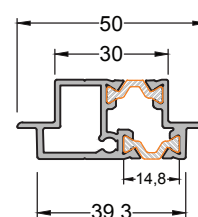
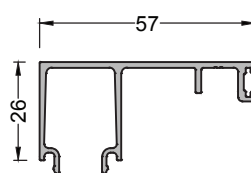
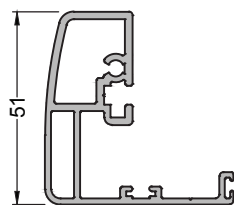
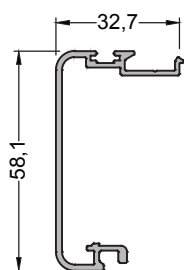

320-6009 (0,522 kg/mt)
SAT120C03 ADAPTER PROFILE

320-6005 (1,059 kg/mt)
SAT120A04 ADAPTER PROFILE

320-6008 (0,570 kg/mt)
SAT120C02 ADAPTER PROFILE

320-6002 (0,760 kg/mt)
SAT120A01 ADAPTER PROFILE

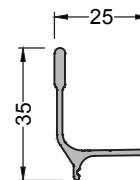
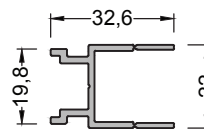
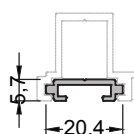
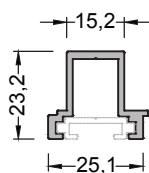

320-6003 (0,388 kg/mt)
SAT120A02 ROD ADAPTER

320-6004 (0,141 kg/mt)
SAT120A03 ROD ADAPTER

320-6010 (0,392 kg/mt)
SAT120A05 ADAPTER PROFILE

320-6001 (0,276 kg/mt)
SAT120S01 WEATHER BAR

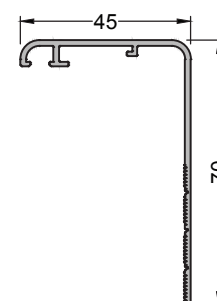
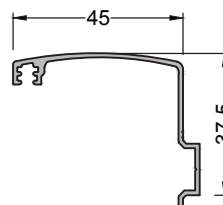
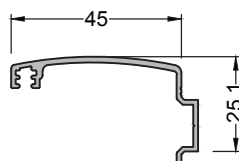
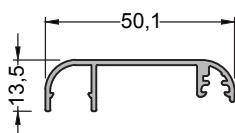

801-135 (0,357 kg/mt)
AW12 SILL PROFILE

801-288 (0,347 kg/mt)
AW02 SILL PROFILE

801-410 (0,349 kg/mt)
AW03 SILL PROFILE

801-070 (0,525 kg/mt)
AW13 SILL PROFILE

SAT 120 S / LS

SLIDING SYSTEM

ACCURACY

HARMONY

BALANCE

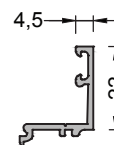
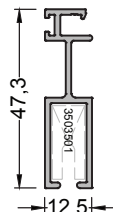
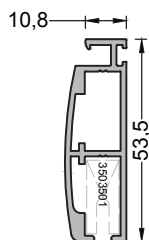
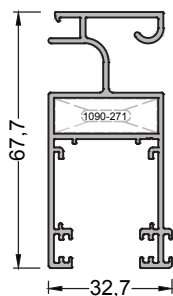

380-4006 (1,003 kg/mt)
SLA-S01 FLYSCREEN VENT PR.

380-4003 (0,661 kg/mt)
S72S03 FLYSCREEN VENT PR.

380-4002 (0,427 kg/mt)
SLA-S02 FLYSCREEN VENT PR.

800-045 (0,227 kg/mt)
G045 GLAZING BEAD

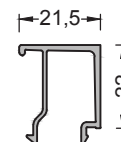
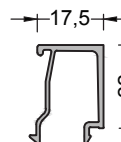
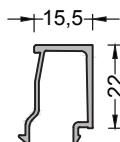
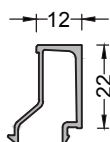
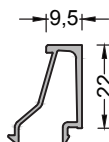

800-095 (0,232 kg/mt)
G095 GLAZING BEAD

800-120 (0,237 kg/mt)
G120 GLAZING BEAD

800-155 (0,249 kg/mt)
G155 GLAZING BEAD

800-175 (0,258 kg/mt)
G175 GLAZING BEAD

800-215 (0,273 kg/mt)
G215 GLAZING BEAD

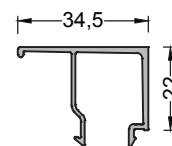
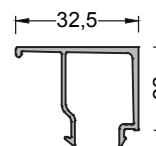
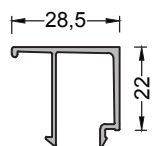
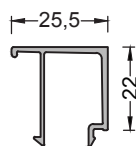
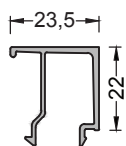

800-235 (0,280 kg/mt)
G235 GLAZING BEAD

800-255 (0,285 kg/mt)
G255 GLAZING BEAD

800-285 (0,296 kg/mt)
G285 GLAZING BEAD

800-325 (0,313 kg/mt)
G325 GLAZING BEAD

800-345 (0,319 kg/mt)
G345 GLAZING BEAD

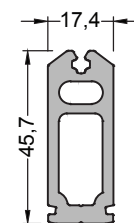
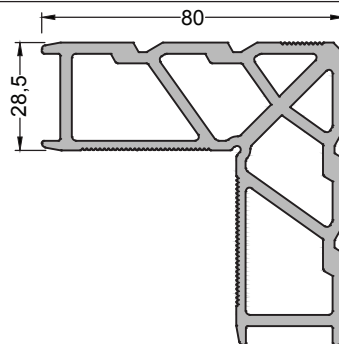
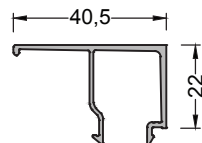
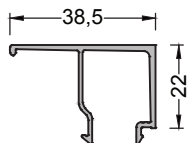

800-385 (0,332 kg/mt)
G385 GLAZING BEAD

800-405 (0,337 kg/mt)
G405 GLAZING BEAD

1285 (3,511 kg/mt)
L285 CORNER JOINT

2198 (1,170 kg/mt)
CONNECTION PROFILE

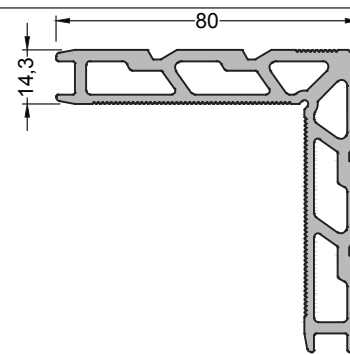
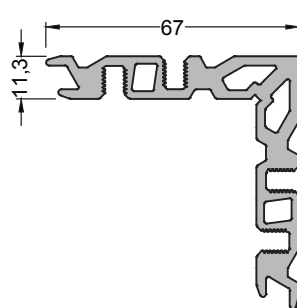
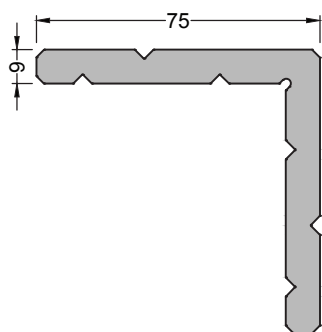

1090 (3,284 kg/mt)
L090 CORNER JOINT

1113 (2,188 kg/mt)
L113 CORNER JOINT

1143 (2,867 kg/mt)
L143 CORNER JOINT

SAT 120 S / LS

SLIDING SYSTEM

ACCURACY

HARMONY

BALANCE

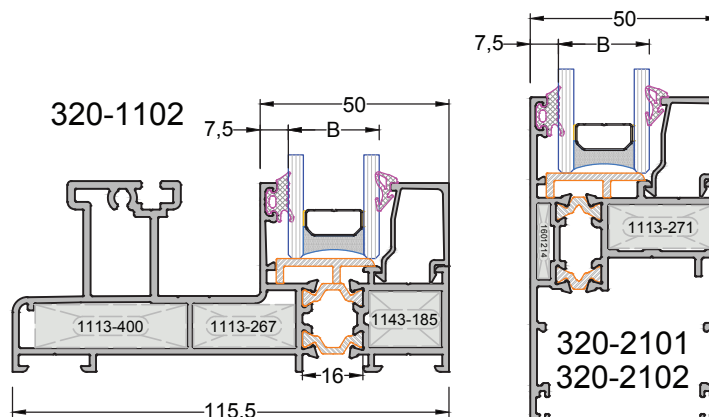
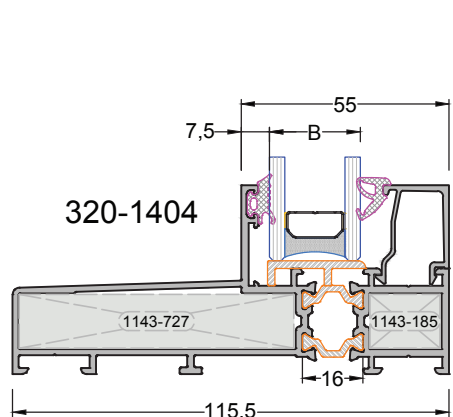

GLASS THICKNESS	EXTERIOR GASKET		INTERIOR GLAZING GASKET				GLAZING BEAD
	3202206 3 mm	3202113 2-3 mm	3202114 4-5 mm	3202115 6-7 mm	3202116 8-9 mm		
4 mm	●					●	800-345
5 mm	●					●	800-345
6 mm	●					●	800-345
8 mm	●		●			●	800-345
10 mm	●	●				●	800-345
12 mm	●					●	800-285
16 mm	●	●				●	800-285
18 mm	●		●			●	800-255
20 mm	●	●				●	800-255
22 mm	●					●	800-175
24 mm	●			●		●	800-175
26 mm	●		●			●	800-175
28 mm	●	●				●	800-175
30 mm	●					●	800-095
32 mm	●			●		●	800-095
34 mm	●		●			●	800-095
36 mm	●	●				●	800-095

GLASS THICKNESS	EXTERIOR GASKET		INTERIOR GLAZING GASKET				GLAZING BEAD
	3202206 3 mm	3202113 2-3 mm	3202114 4-5 mm	3202115 6-7 mm	3202116 8-9 mm		
4 mm	●					●	800-325
5 mm	●					●	800-325
6 mm	●					●	800-325
8 mm	●		●			●	800-285
10 mm	●	●				●	800-285
12 mm	●					●	800-285
16 mm	●	●				●	800-215
18 mm	●		●			●	800-215
20 mm	●	●				●	800-155
22 mm	●					●	800-155
24 mm	●			●		●	800-155
26 mm	●		●			●	800-095
28 mm	●	●				●	800-095
30 mm	●					●	800-095
32 mm	●			●		●	800-045
34 mm	●		●			●	800-045
36 mm	●	●				●	800-045

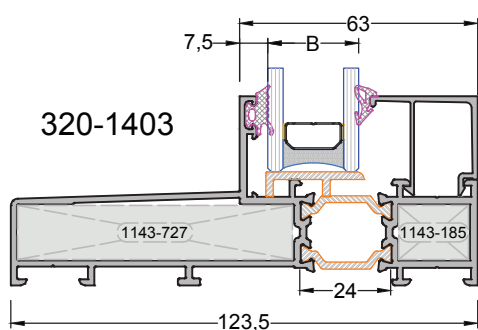

GLASS THICKNESS	EXTERIOR GASKET		INTERIOR GLAZING GASKET				GLAZING BEAD
	3202206 3 mm	3202113 2-3 mm	3202114 4-5 mm	3202115 6-7 mm	3202116 8-9 mm		
8 mm	●					●	800-405
10 mm	●					●	800-405
12 mm	●		●			●	800-405
16 mm	●					●	800-345
18 mm	●	●				●	800-345
20 mm	●					●	800-285
22 mm	●		●			●	800-285
24 mm	●	●				●	800-285
26 mm	●			●		●	800-235
28 mm	●	●				●	800-235
30 mm	●	●				●	800-235
32 mm	●					●	800-175
34 mm	●		●			●	800-175
36 mm	●	●				●	800-175

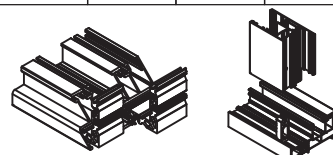

CORNER BLOCK CONNECTION PROFILE SELECTION LIST

PROFILE CODE	UNIT CODE	CUTTING SIZE	CORNER JOINT
	1113-400	40,0 mm	1113
	1113-477	47,7 mm	
	1113-400	40,0 mm	1113
	1113-329	32,9 mm	
	1113-477	47,7 mm	1113
	1113-400	40,0 mm	
	1113-267	26,7 mm	1143
	1143-185	18,5 mm	
	1113-347	34,7 mm	1113
	1113-477	47,7 mm	
	1143-727	72,7 mm	1143
	1143-185	18,5 mm	
	1143-727	72,7 mm	1143
	1143-185	18,5 mm	
	1601209	KÖŞE ÇAVUŞ	1113
	1113-271	27,1 mm	
	1601214	KÖŞE ÇAVUŞ	1113
	1113-271	27,1 mm	

PROFILE CODE	CODE	CUTTING SIZE	CONNECTION PROFILE
320-2101 320-2102	2198-113	11,3 mm	2198

SAT 120 S / LS

SLIDING SYSTEM



ACCURACY

HARMONY

BALANCE

DRAWING	CODE	NAME
	3202206	GLAZING GASKET 3 MM
	3202113	GLAZING GASKET 2-3 MM
	3202114	GLAZING GASKET 4-5 MM
	3202115	GLAZING GASKET 6-7 MM
	3202116	GLAZING GASKET 8-9 MM
	3202302	ACOUSTICAL GASKET
	3202603	RAIL GASKET
	3202704	CONNECTION GASKET
	3202604	SEALING GASKET
	6502601	GASKET
	3203009	BRUSH 6,7x550
	3203007	BRUSH 6,7x550
	3203002	BRUSH 4,8x650
	7803102	PVC CENTER PROFILE
	7803105	PVC CONNECTION PROFILE
	3503910	WEATHER STRIP
	3501903	WEATHER STRIP
	3503906	SEALING PART
	3503907	SEALING PART
	3503908	SEALING PART
	3503909	SEALING PART
	3501904	SPACER
	5303208	PVC GLASS SUPPORT

DRAWING	CODE	NAME
	1601952	PVC SILL ADAPTER
	6503406	PVC SWATTER VENT CORNER JOINT
	3507902	STEEL RAIL
	3503600	VENT CAP
	3501510	ROLLER
	3501512	ROLLER
	3501509	SWATTER ROLLER
	0201017	HANDLE
	0201018	HANDLE
	0101933	PVC WINDOW HANDLE
	0101934	PVC WINDOW HANDLE / RIGHT
	0101935	PVC WINDOW HANDLE / LEFT
	3601102	HANDLE
	3516060	PVC ESPAGNOLETTE 600/25
	3516080	PVC ESPAGNOLETTE 800/25
	3516100	PVC ESPAGNOLETTE 1000/25
	3516140	PVC ESPAGNOLETTE 1400/25
	3516160	PVC ESPAGNOLETTE 1600/25
	3516180	PVC ESPAGNOLETTE 1800/25
	3501300	STRIKER FOR SLIDING LOCK
	0301100	SLIDING LOCK
	0301103	SLIDING LOCK
	0301104	SLIDING LOCK

DRAWING	CODE	NAME
	3501920	STRIKER FOR SLIDING LOCK
	233004	FIXED BOGIE
	2311	HANDLE WITH LOCK
	2312	HANDLE WITH LOCK
	2315	HANDLE WITH LOCK
	2316	HANDLE WITH LOCK
	2313	HANDLE WITH LOCK
	2314	HANDLE WITH LOCK
	234101	SINGLE SASH LOCKING KIT WITHOUT WEDGE
	235203	PLASTIC WEDGES KIT
	236004	14 MM WEDGE SCREW KIT
	233001	LIFT & SLIDE FRONT BOGIE
	233002	REAR LIFT AND SLIDE BOGIE
	233004	LIFT AND SLIDE SUPPLEMENTARY BOGIE
	234001	LIFT & SLIDE DRIVE GEAR - 2100 mm
	234002	LIFT & SLIDE DRIVE GEAR - 2400 mm
	234003	LIFT & SLIDE DRIVE GEAR - 2700 mm
	234004	LIFT & SLIDE DRIVE GEAR - 1800 mm
	1601200	CORNER CLEAT
	1601201	CORNER CLEAT
	160301	CORNER CLEAT
	1601209	CORNER CLEAT
	1601214	CORNER CLEAT

SAT 120 S / LS

SLIDING SYSTEM



ACCURACY

HARMONY

BALANCE

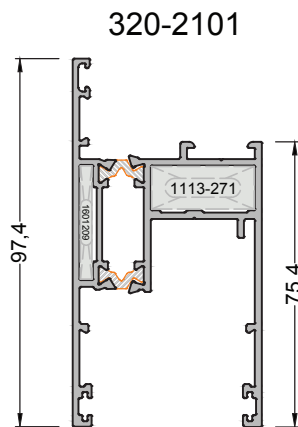

DRAWING	CODE	NAME
	3501801	PVC ESPAGNOLETTE ADAPTER PROFILE 600 mm
	3501802	PVC ESPAGNOLETTE ADAPTER PROFILE 800 mm
	3501803	PVC ESPAGNOLETTE ADAPTER PROFILE 1000 mm
	3501804	PVC ESPAGNOLETTE ADAPTER PROFILE 600 mm
	3501805	PVC ESPAGNOLETTE ADAPTER PROFILE 600 mm
	3501806	PVC ESPAGNOLETTE ADAPTER PROFILE 600 mm
	3501807	PVC ESPAGNOLETTE ADAPTER PROFILE 600 mm
	3501808	PVC ESPAGNOLETTE ADAPTER PROFILE 600 mm

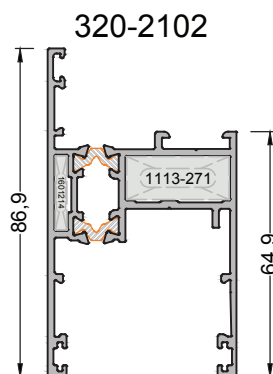

DRAWING	CODE	NAME
	3501809	PVC ESPAGNOLETTE ADAPTER PROFILE 600 mm
	3501810	PVC ESPAGNOLETTE ADAPTER PROFILE 800 mm
	3501811	PVC ESPAGNOLETTE ADAPTER PROFILE 1000 mm
	3501812	PVC ESPAGNOLETTE ADAPTER PROFILE 600 mm
	3501813	PVC ESPAGNOLETTE ADAPTER PROFILE 600 mm
	3501814	PVC ESPAGNOLETTE ADAPTER PROFILE 600 mm
	3501815	PVC ESPAGNOLETTE ADAPTER PROFILE 600 mm
	3501816	PVC ESPAGNOLETTE ADAPTER PROFILE 600 mm

SAT 120 S / LS

SLIDING SYSTEM



ACCURACY



HARMONY



BALANCE

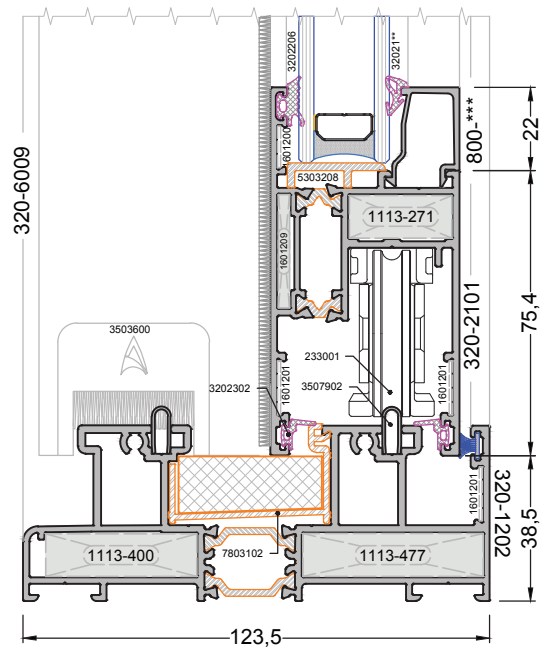
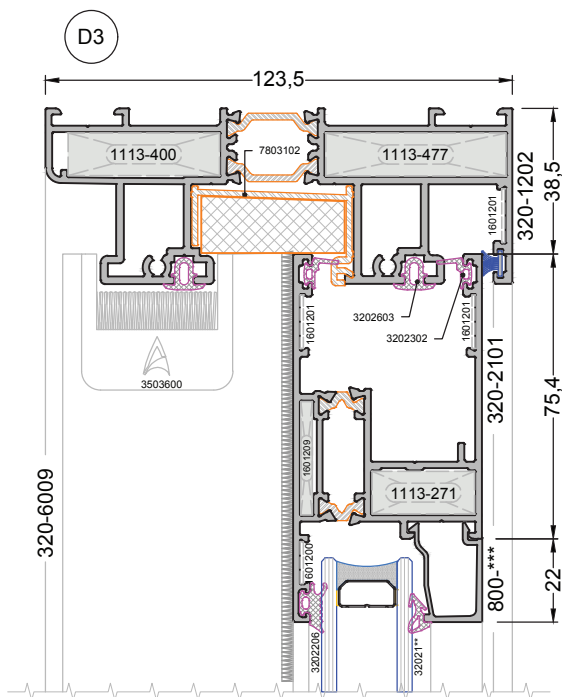
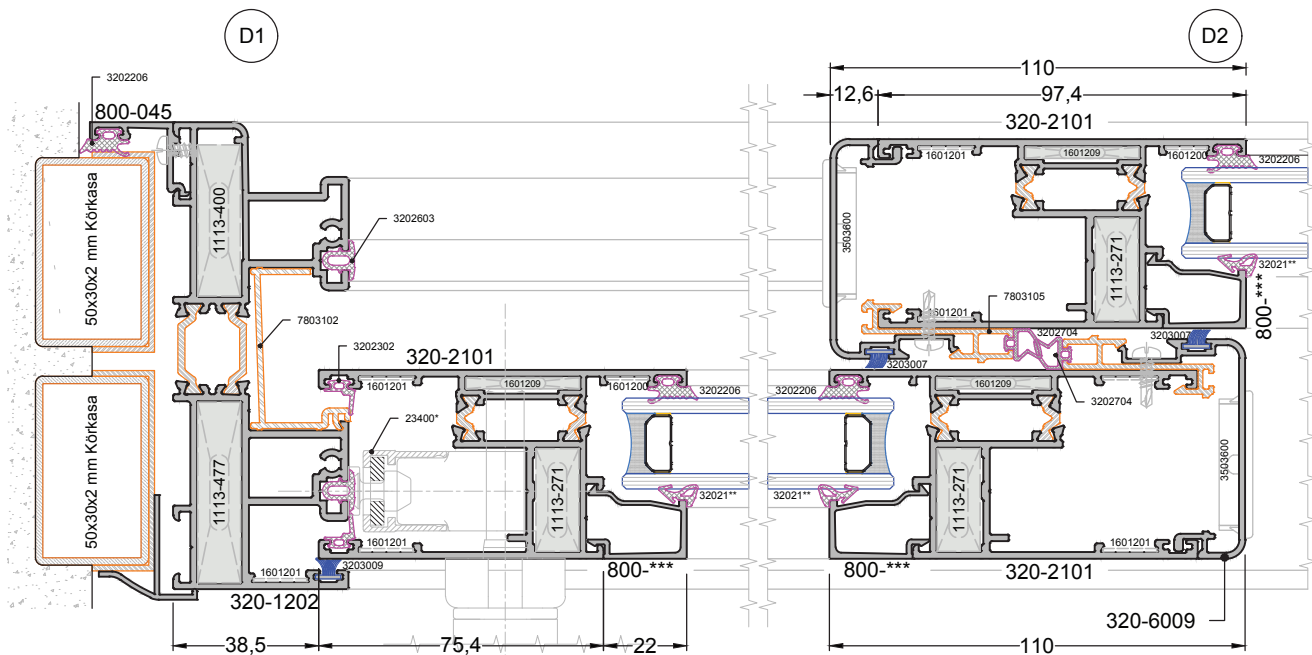
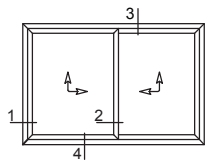

SAT 120 S / LS

SLIDING SYSTEM

ACCURACY

HARMONY

BALANCE

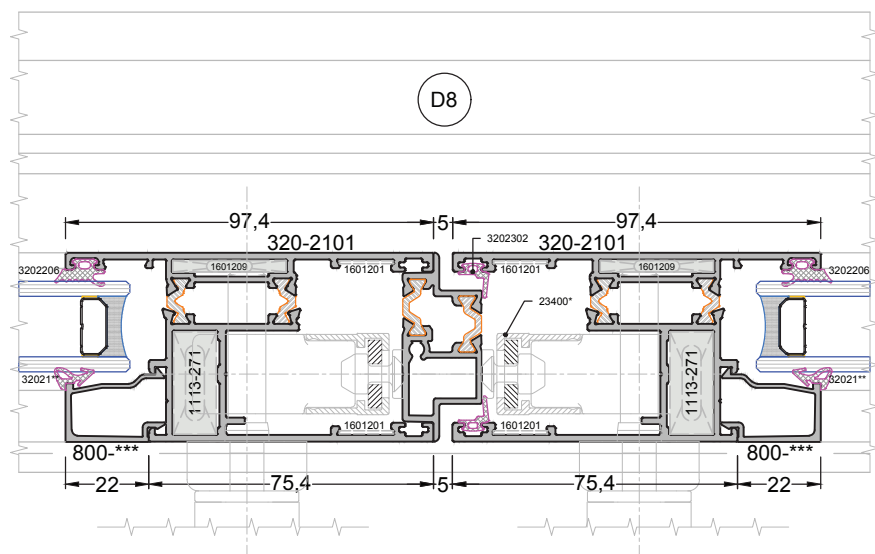
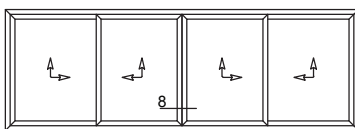
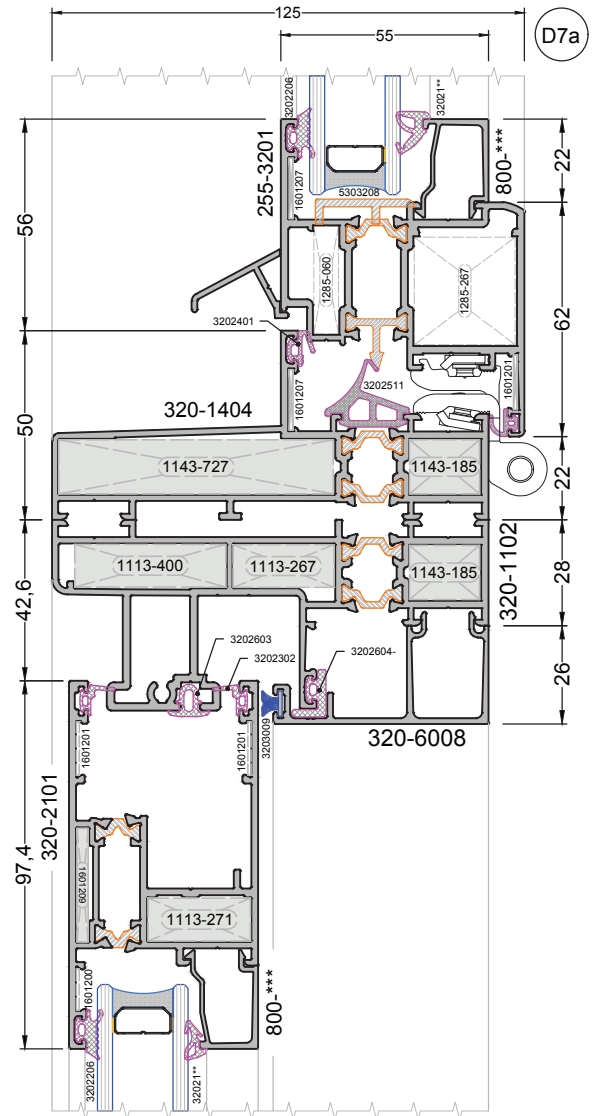
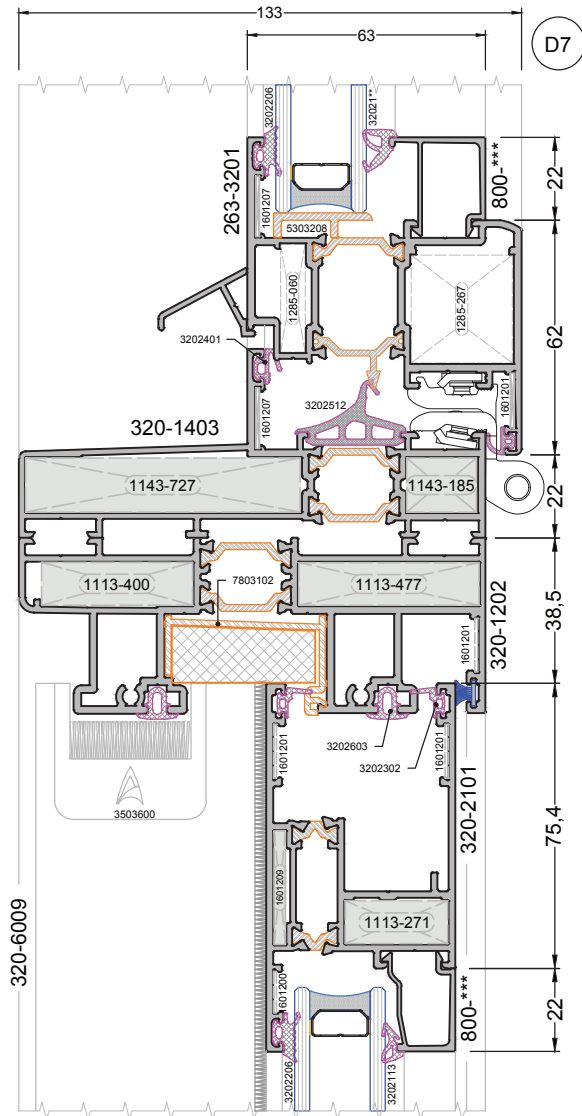
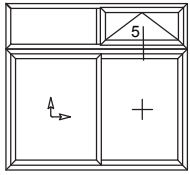

SAT 120 S / LS

SLIDING SYSTEM

ACCURACY

HARMONY

BALANCE

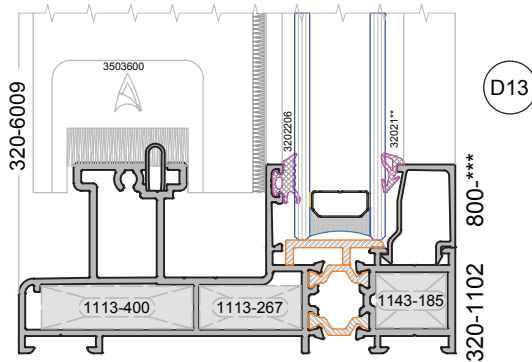
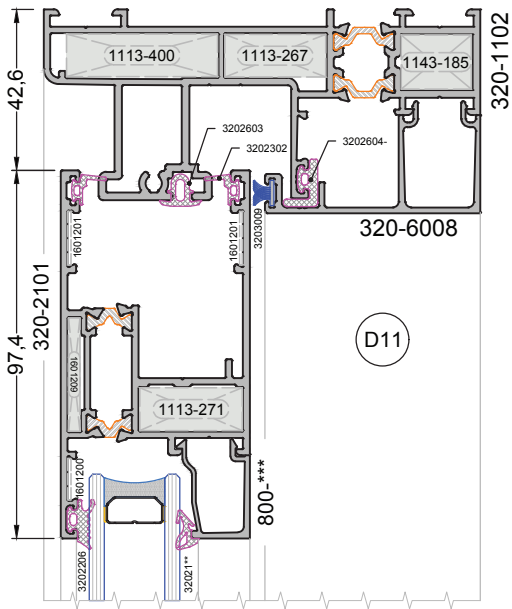
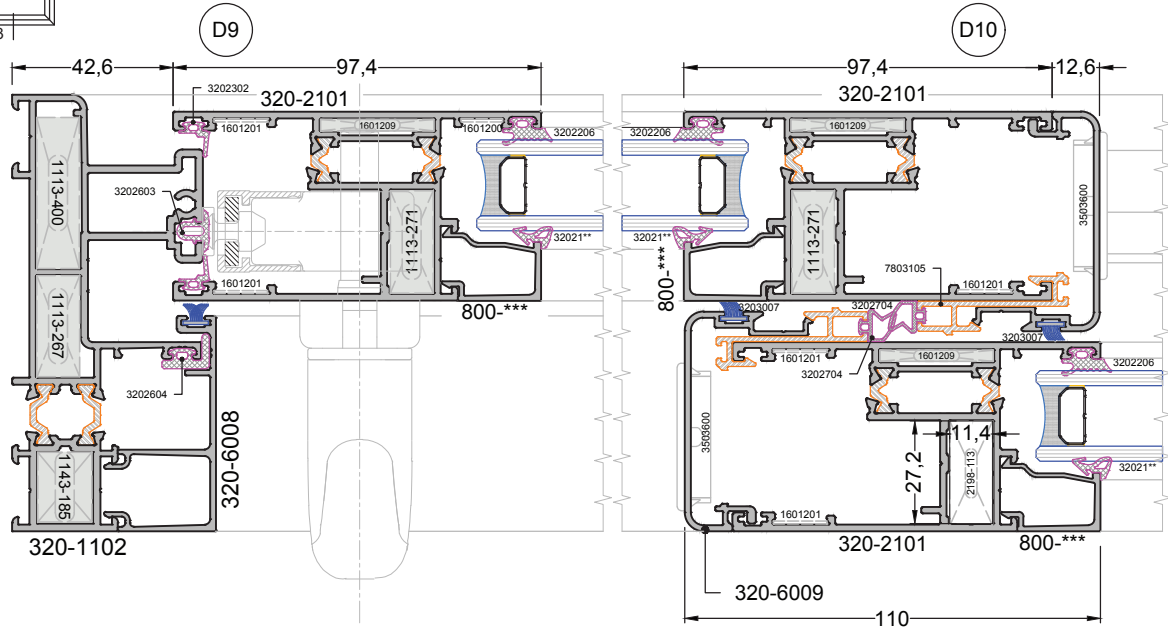
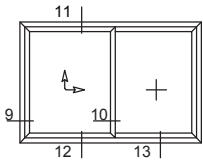

SAT 120 S / LS

SLIDING SYSTEM

ACCURACY

HARMONY

BALANCE

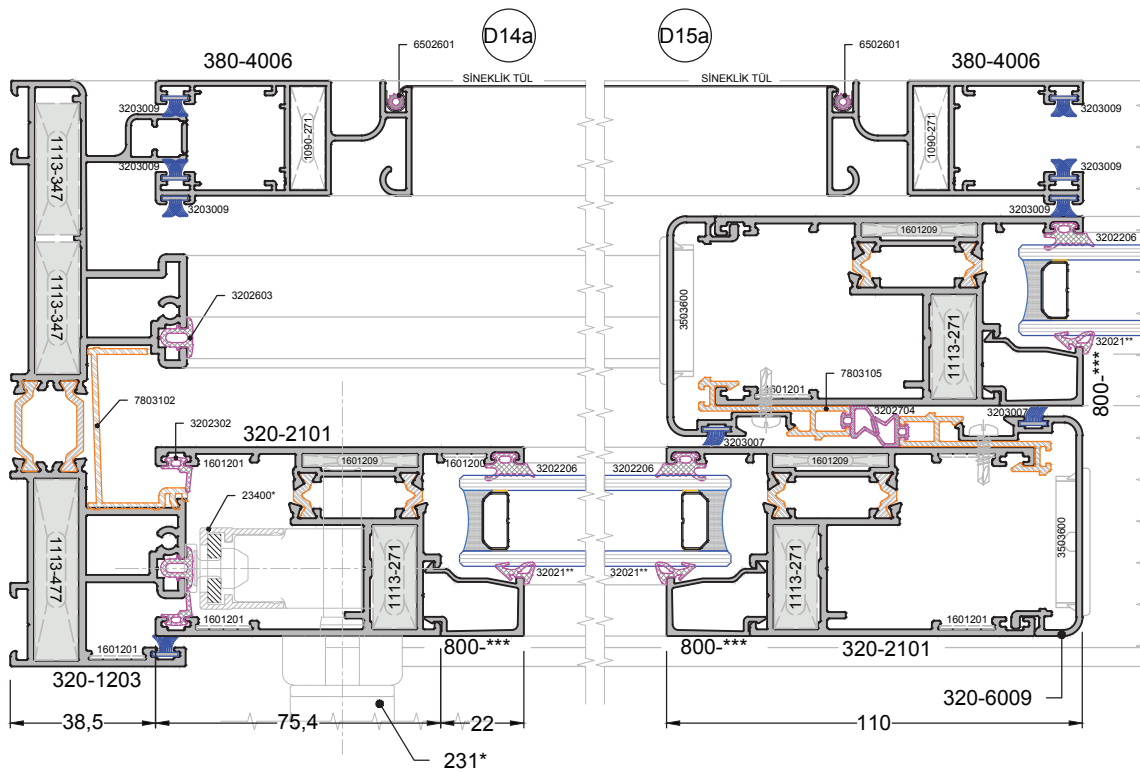
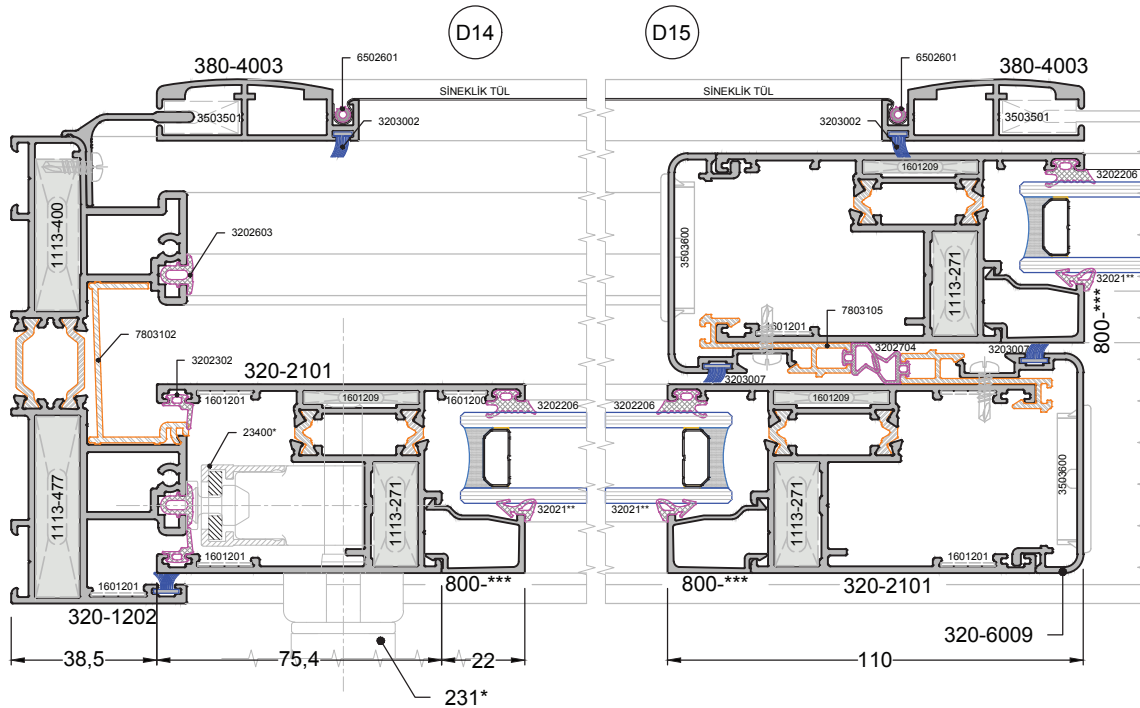
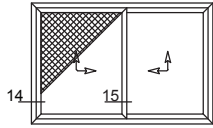

SAT 120 S / LS

SLIDING SYSTEM

ACCURACY

HARMONY

BALANCE

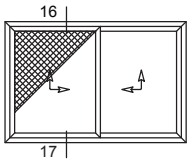

D16

D16a

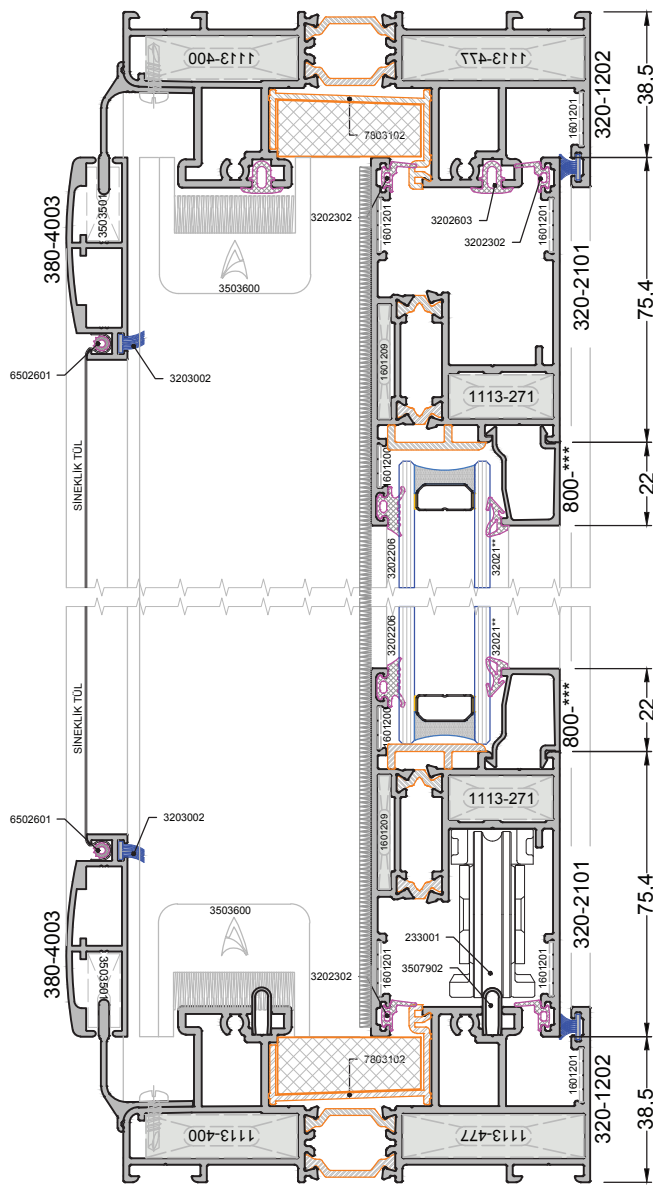

D17

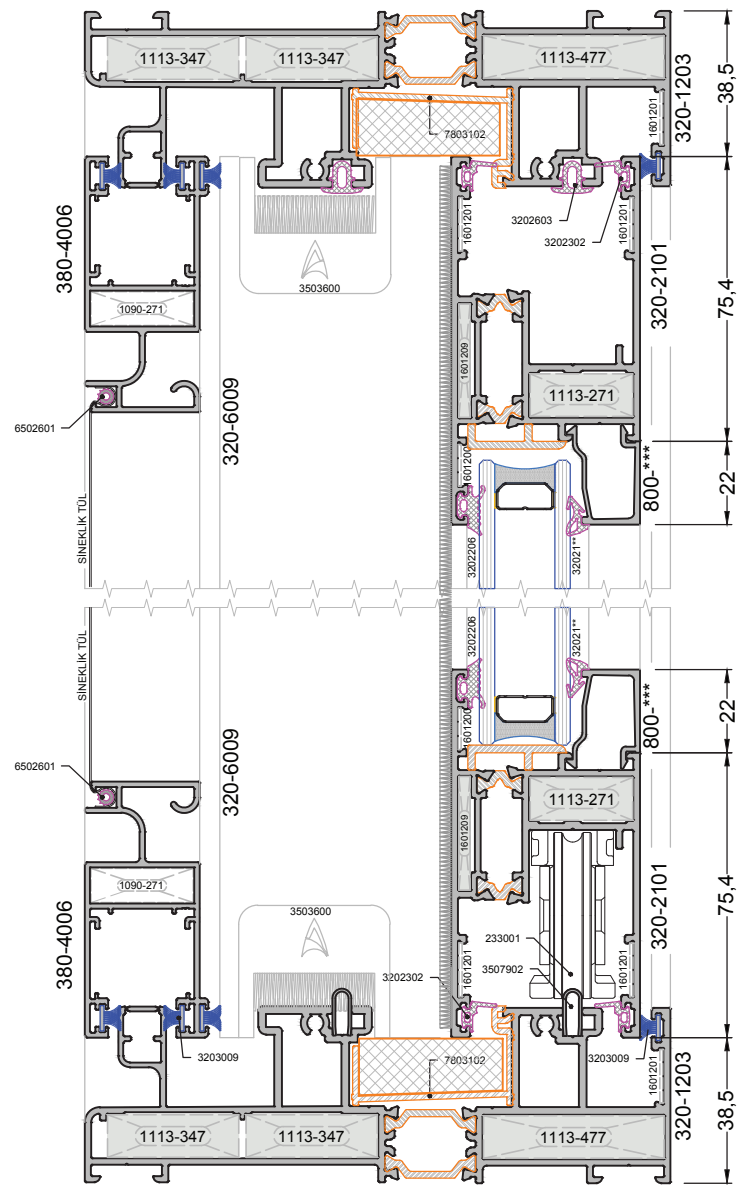

D17a

SAT 120 S / LS

SLIDING SYSTEM

ACCURACY

HARMONY

BALANCE

